

# 扁平タイプ(流体軸受) Flat model(Hydrodynamic bearing)

UDQFMKH01 - 9'

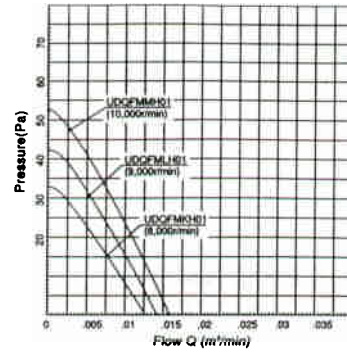

UDQFNMH21

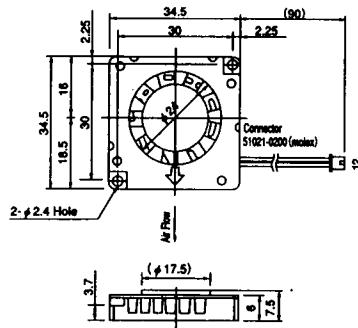
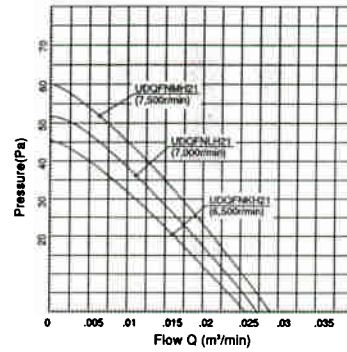
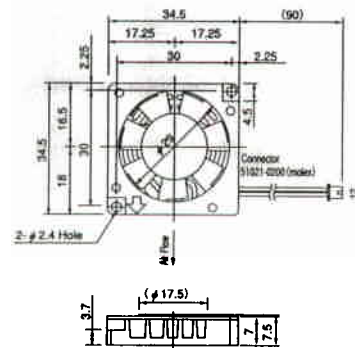

UDQFULH01

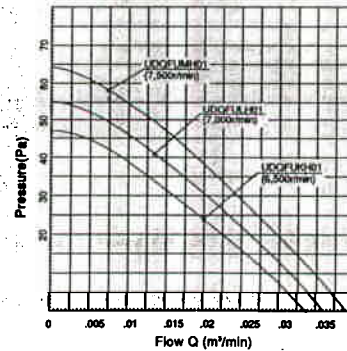
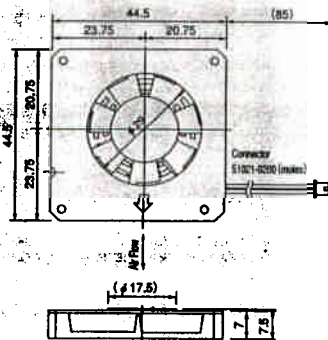

UDQFSEH01

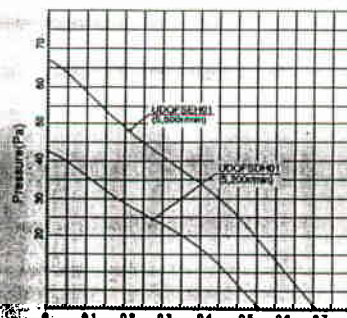
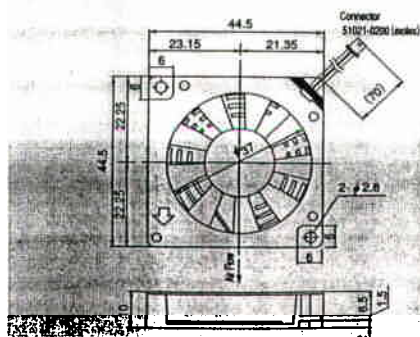

# 縦型タイプ (2ボールベアリング)

## Vertical model (2ball bearings)

UDQFBAB01

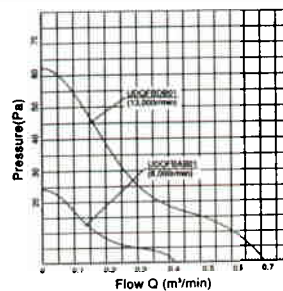
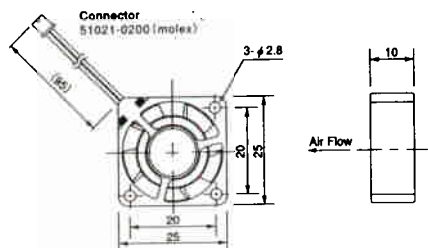

UDQFDAB01

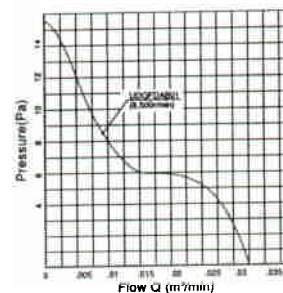
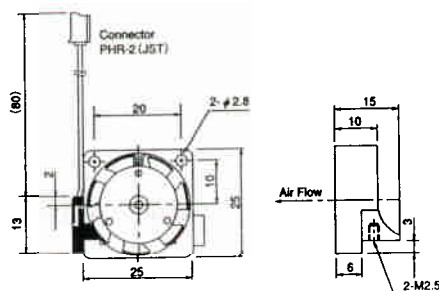
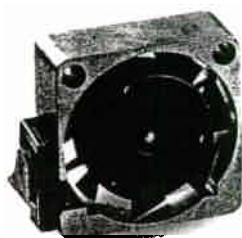

UDQFHBB01

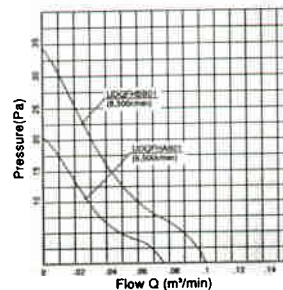
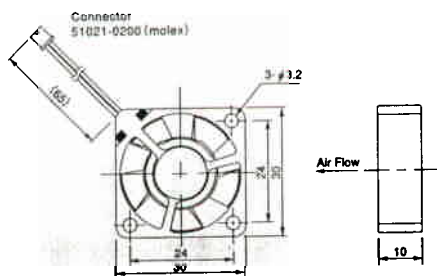
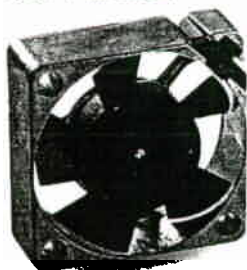

UDQFFAB01

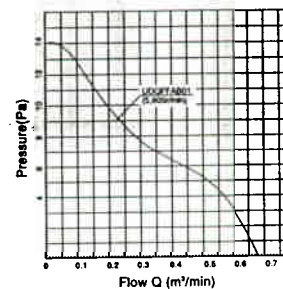
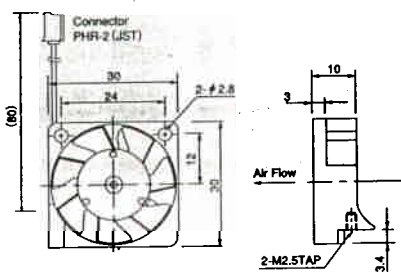
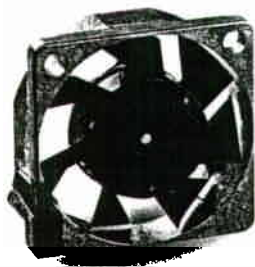

UDQFHAB05F  
(樹脂フレーム)



(Plastic frame type)

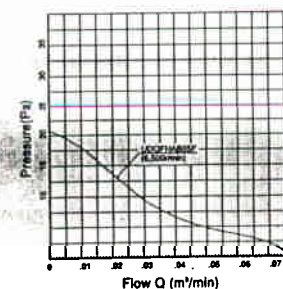
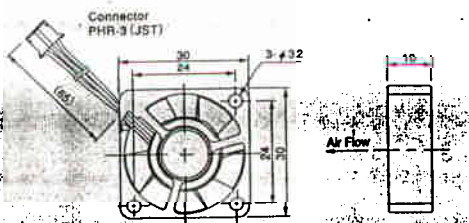

MPU冷却ファン性能一覧表

タイプ (Type)	代表機種名 (Model)	定 格		at 25℃		at 60℃		at 60℃ 相当			
		定格電圧 (Rated voltage) (V)	定格電流 (Rated current) (mA)	電 流 (Current) (mA)	回転数 (Speed) (r/min)	電 流 (Current) (mA)	回転数 (Speed) (r/min)	最大風量 (Max air flow) (m³/min) (CFM)	最大静圧 (Max air pressure) (Pa) (in H₂O)	騒音 (dB)	
扁平タイプ	□35 (6mm)	UDQFMKH01	5.0	140	140	6,000	125	8,000	0.012 (0.43)	32.0 (0.13)	25.0
		UDQFMLH01	5.0	195	195	7,000	175	9,000	0.014 (0.5)	42.0 (0.17)	28.0
		UDQFMMH01	5.0	240	240	8,000	225	10,000	0.016 (0.57)	52.0 (0.21)	31.5
	□35 (7mm)	UDQFNKH21	5.0	140	140	5,000	125	6,500	0.025 (0.90)	45.0 (0.18)	26.0
		UDQFNLH21	5.0	195	195	5,500	175	7,000	0.027 (0.96)	52.0 (0.21)	28.0
		UDQFNMH21	5.0	240	240	6,000	225	7,500	0.028 (1.0)	60.0 (0.24)	30.0
	□45 (7mm)	UDQFUKH01	5.0	140	140	5,000	125	6,500	0.033 (1.2)	47.0 (0.19)	29.0
		UDQFULH01	5.0	195	195	5,500	175	7,000	0.036 (1.3)	55.0 (0.22)	32.0
		UDQFUMH01	5.0	240	240	6,000	225	7,500	0.039 (1.4)	65.0 (0.26)	33.0
□45 (10mm)	UDQFSDH01	5.0	170	170	4,500	155	5,200	0.056 (2.0)	42.0 (0.17)	30.0	
	UDQFSEH01	5.0	220	220	5,000	200	5,500	0.070 (2.5)	65.0 (0.26)	33.0	
縦型タイプ	□25 (10mm)	UDQFBAB01	5.0	70	70	5,800	60	8,000	0.043 (1.5)	25.0 (0.10)	20.0
		UDQFBDB01	5.0	150	150	11,000	130	13,000	0.070 (2.0)	60.0 (0.24)	29.0
	□25足付 (10mm)	UDQFDAB01	5.0	65	65	6,700	55	8,500	0.032 (1.1)	15.0 (0.06)	36.0
	□30 (10mm)	UDQFHAB01	5.0	70	70	5,500	65	6,500	0.075 (2.7)	20.0 (0.08)	20.0
		UDQFHBB01	5.0	100	100	7,000	90	8,500	0.100 (3.6)	35.0 (0.14)	26.0
		UDQFHAB05F	5.0	70	70	5,500	65	6,500	0.075 (2.7)	20.0 (0.08)	20.0
	□30足付 (10mm)	UDQFFAB01	5.0	75	75	4,700	70	5,600	0.067 (2.4)	14.0 (0.06)	21.0

(FGセンサ付・サーミスタ付も対応可能です。)

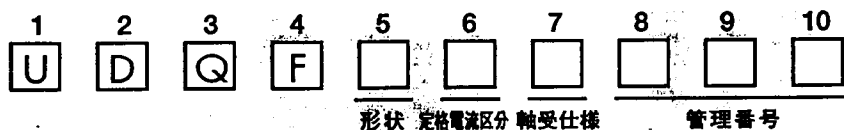

Model with FG sensors and Thermistor models also available.

品番呼称/体系



\*Dimensions and details may change without notice.

寸法その他詳細については改善のため予告なく変更することがあります。

 <b>Safety caution</b> ●Please use correctly after checking the specifications.	 <b>安全に関するご注意</b> ●ご使用の際は、納入仕様書をご確認のうえ正しくお使いください。
---	---

Matsushita Electric Industrial Co.,Ltd  
 Kyushu Matsushita Electric Co.,Ltd  
 Precision Devices and Components Division  
 2111 Ueda Usa Oita Japan 879-0493  
 Tel(0978)37-1991 Fax(0978)37-3502

お問い合わせは……  
 For further information...

松下電器産業株式会社  
 九州松下電器株式会社

精密デバイス事業部  
 〒879-0493 大分県宇佐市上田2111

TEL0978-37-1991 FAX0978-37-3502  
 このカタログについてのお問い合わせは左記にご相談ください。  
 または当社におたずねください。

このカタログの記載事項は  
 2000年1月現在のものです。

●製品の色は印刷物ですので実際の色と若干異なる場合があります。●製品の定格およびデザインは改善等のため予告なく変更する場合があります。

上手に使うって上手に節電