



General Specifications

Motor Protection:

Auto Restart/Polarity Protection

Insulation Resistance: 10M Ω or over with a DC500V Megger

Dielectric Withstand Voltage: AC 700V 1s

Allowable Ambient Temperature Range:

-10°C ~ +60°C (Operating)

-40°C ~ +70°C (Operating)

(non-condensing environment)

Expected Life

Failure Rate: 10%

25°C 70,000 Hours (L00)

25°C 60,000 Hours (T00)

Outline

Units: $\frac{\text{inch}}{\text{mm}}$

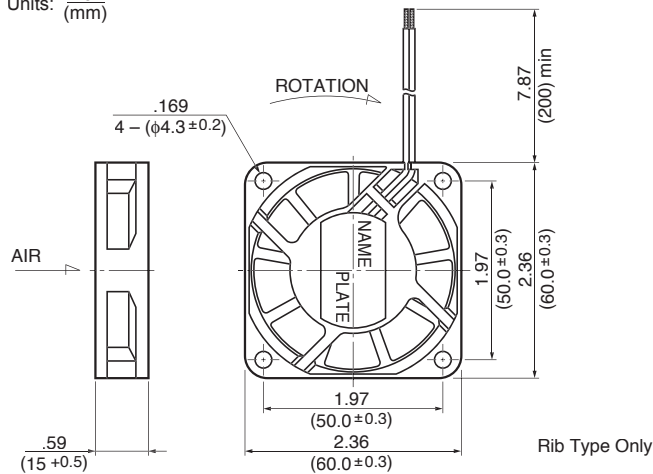

Characteristic Curves

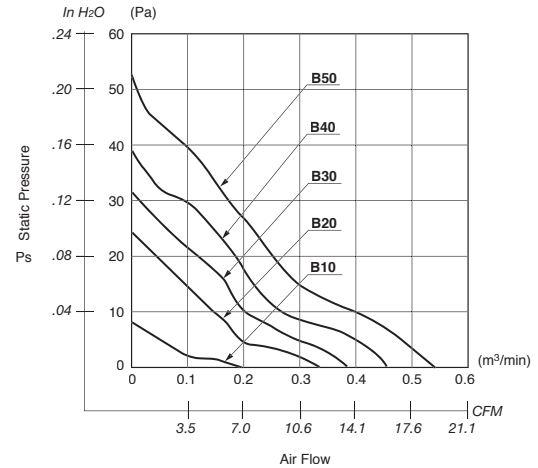

Panel Cut-outs

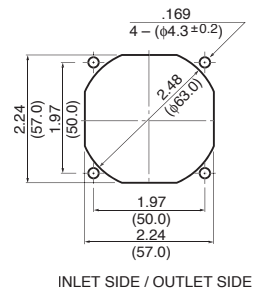

Material

Casing : Plastic (Black) 94V-0

Impeller : Plastic (Black) 94V-0

Bearing : Ball Bearing

Lead Wire : UL1007, AWG26, +Red, -Black

Specifications

MODEL	Product No.	Rated Voltage	Operating Voltage	Current	Input Power	Speed	Max. Air Flow		Max. Static Pressure		Noise	Mass
		(V)	(V)	(A) ^{*1}	(W) ^{*1}	(min ⁻¹) ^{*1}	CFM ^{*1}	(m ³ /min) ^{*1}	in H ₂ O	(Pa) ^{*1}	(dB) ^{*1}	(g)
2406KL-04W-B10-	X00	12	7.0 ~ 13.8	0.04	0.48	1800	6.7	0.19	.03	8.5	19.0	45
2406KL-04W-B20-	X00	12	6.0 ~ 13.8	0.07	0.84	3100	11.6	0.33	.09	23.4	25.0	45
2406KL-04W-B30-	X00	12	6.0 ~ 13.8	0.09	1.08	3600	14.1	0.40	.13	31.3	28.0	45
2406KL-04W-B40-	X00	12	6.0 ~ 13.8	0.13	1.56	4100	15.9	0.45	.16	39.7	31.0	45
2406KL-04W-B50-	X00	12	6.0 ~ 13.8	0.16	1.92	4600	18.3	0.52	.20	51.2	34.0	45
2406KL-05W-B10-	X00	24	18.5 ~ 27.6	0.04	0.96	1800	6.7	0.19	.03	8.5	19.0	45
2406KL-05W-B20-	X00	24	12.0 ~ 27.6	0.06	1.44	3100	11.6	0.33	.09	23.4	25.0	45
2406KL-05W-B30-	X00	24	12.0 ~ 27.6	0.06	1.44	3600	14.1	0.40	.13	31.3	28.0	45
2406KL-05W-B40-	X00	24	10.0 ~ 27.6	0.07	1.68	4100	15.9	0.45	.16	39.7	31.0	45
2406KL-05W-B50-	X00	24	10.0 ~ 27.6	0.10	2.40	4600	18.3	0.52	.20	51.2	34.0	45

Rotation: Clockwise

Airflow Outlet: Air Out Over Struts

*1: Average Values in Free Air

For information on 2406KL-04W-B80 contact the sales office.